



National
Qualifications
2019

X847/76/11

**Mathematics
Paper 1 (Non-calculator)**

THURSDAY, 2 MAY
9:00 AM – 10:30 AM

Total marks — 70

Attempt ALL questions.

You may NOT use a calculator.

To earn full marks you must show your working in your answers.

State the units for your answer where appropriate.

You will not earn marks for answers obtained by readings from scale drawings.

Write your answers clearly in the spaces provided in the answer booklet. The size of the space provided for an answer is not an indication of how much to write. You do not need to use all the space.

Additional space for answers is provided at the end of the answer booklet. If you use this space you must clearly identify the question number you are attempting.

Use **blue** or **black** ink.

Before leaving the examination room you must give your answer booklet to the Invigilator; if you do not, you may lose all the marks for this paper.



* X 8 4 7 7 6 1 1 *

FORMULAE LIST

Circle

The equation $x^2 + y^2 + 2gx + 2fy + c = 0$ represents a circle centre $(-g, -f)$ and radius $\sqrt{g^2 + f^2 - c}$.

The equation $(x - a)^2 + (y - b)^2 = r^2$ represents a circle centre (a, b) and radius r .

Scalar product

$\mathbf{a} \cdot \mathbf{b} = |\mathbf{a}| |\mathbf{b}| \cos \theta$, where θ is the angle between \mathbf{a} and \mathbf{b}

or $\mathbf{a} \cdot \mathbf{b} = a_1 b_1 + a_2 b_2 + a_3 b_3$ where $\mathbf{a} = \begin{pmatrix} a_1 \\ a_2 \\ a_3 \end{pmatrix}$ and $\mathbf{b} = \begin{pmatrix} b_1 \\ b_2 \\ b_3 \end{pmatrix}$.

Trigonometric formulae

$$\sin(A \pm B) = \sin A \cos B \pm \cos A \sin B$$

$$\cos(A \pm B) = \cos A \cos B \mp \sin A \sin B$$

$$\sin 2A = 2 \sin A \cos A$$

$$\cos 2A = \cos^2 A - \sin^2 A$$

$$= 2 \cos^2 A - 1$$

$$= 1 - 2 \sin^2 A$$

Table of standard derivatives

| $f(x)$ | $f'(x)$ |
|-----------|--------------|
| $\sin ax$ | $a \cos ax$ |
| $\cos ax$ | $-a \sin ax$ |

Table of standard integrals

| $f(x)$ | $\int f(x) dx$ |
|-----------|----------------------------|
| $\sin ax$ | $-\frac{1}{a} \cos ax + c$ |
| $\cos ax$ | $\frac{1}{a} \sin ax + c$ |

Attempt ALL questions

Total marks — 70

1. Find the x -coordinates of the stationary points on the curve with equation
 $y = \frac{1}{2}x^4 - 2x^3 + 6$. 4
2. The equation $x^2 + (k - 5)x + 1 = 0$ has equal roots.
Determine the possible values of k . 3
3. Circle C_1 has equation $x^2 + y^2 - 6x - 2y - 26 = 0$.
Circle C_2 has centre $(4, -2)$.
The radius of C_2 is equal to the radius of C_1 .
Find the equation of circle C_2 . 2
4. A sequence is generated by the recurrence relation
$$u_{n+1} = mu_n + c,$$
where the first three terms of the sequence are 6, 9 and 11.
(a) Find the values of m and c . 3
(b) Hence, calculate the fourth term of the sequence. 1
5. (a) Show that the points $A(1, 5, -3)$, $B(4, -1, 0)$ and $C(8, -9, 4)$ are collinear. 3
(b) State the ratio in which B divides AC . 1

6. Given that $y = \frac{1}{(1-3x)^5}$, $x \neq \frac{1}{3}$, find $\frac{dy}{dx}$. 3

7. The line, L , makes an angle of 30° with the positive direction of the x -axis.
Find the equation of the line perpendicular to L , passing through $(0, -4)$. 4

8. The graphs of $y = x^2 + 2x + 3$ and $y = 2x^2 + x + 1$ are shown below.

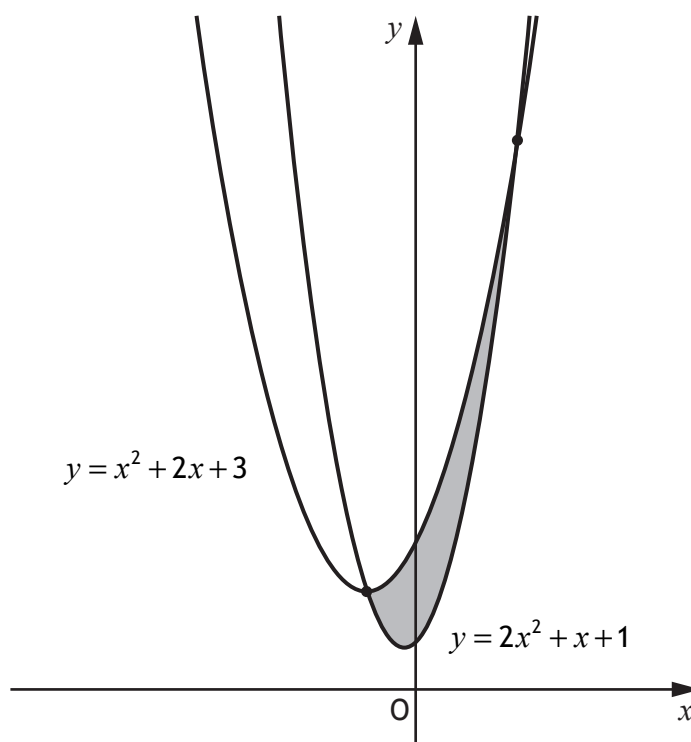

The graphs intersect at the points where $x = -1$ and $x = 2$.

(a) Express the shaded area, enclosed between the curves, as an integral. 1

(b) Evaluate the shaded area. 3

9. Vectors \mathbf{u} and \mathbf{v} have components $\begin{pmatrix} p \\ -2 \\ 4 \end{pmatrix}$ and $\begin{pmatrix} 2p+16 \\ -3 \\ 6 \end{pmatrix}$, $p \in \mathbb{R}$.

- (a) (i) Find an expression for $\mathbf{u} \cdot \mathbf{v}$. 1
- (ii) Determine the values of p for which \mathbf{u} and \mathbf{v} are perpendicular. 3
- (b) Determine the value of p for which \mathbf{u} and \mathbf{v} are parallel. 2

10. The diagram shows the graphs with equations $y = f(x)$ and $y = kf(x) + a$.

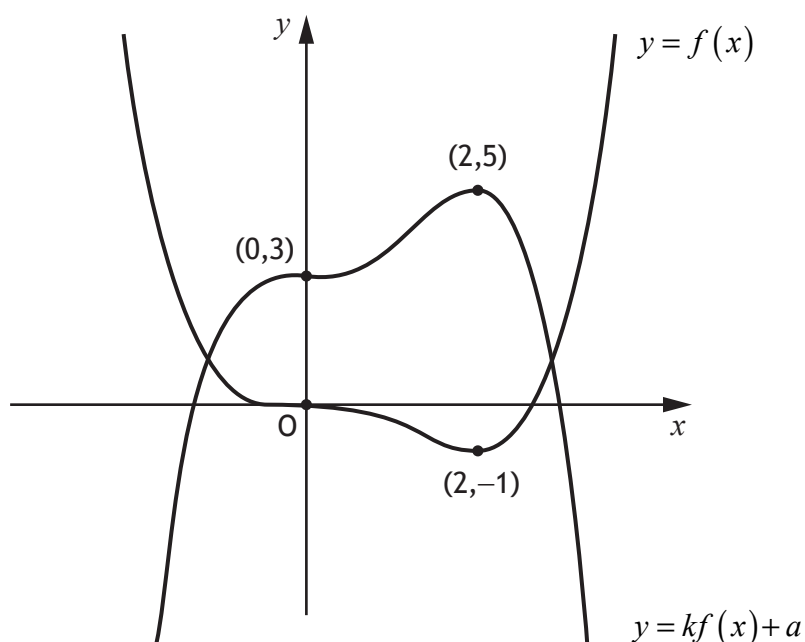

- (a) State the value of a . 1
- (b) Find the value of k . 1

11. Evaluate $\int_0^{\frac{\pi}{9}} \cos\left(3x - \frac{\pi}{6}\right) dx$.

4

12. Functions f and g are defined by

- $f(x) = \frac{1}{\sqrt{x}}$, where $x > 0$
- $g(x) = 5 - x$, where $x \in \mathbb{R}$.

- (a) Determine an expression for $f(g(x))$. 2
- (b) State the range of values of x for which $f(g(x))$ is undefined. 1

13. Triangles ABC and ADE are both right angled.
Angles p and q are as shown in the diagram.

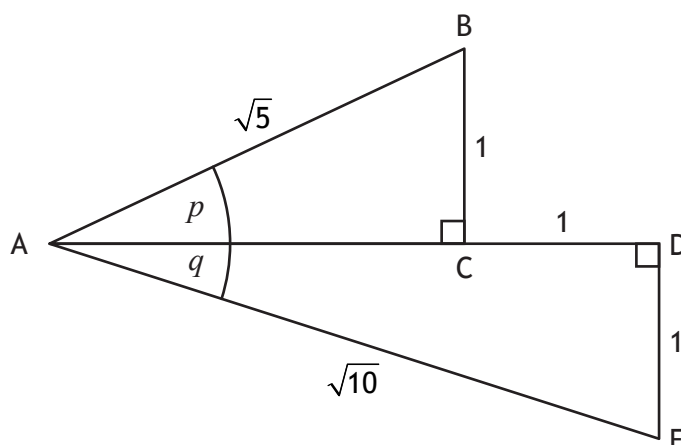

- (a) Determine the value of
- (i) $\cos p$ 1
- (ii) $\cos q$. 1
- (b) Hence determine the value of $\sin(p + q)$. 3

14. (a) Evaluate $\log_{10} 4 + 2\log_{10} 5$. 3
- (b) Solve $\log_2(7x - 2) - \log_2 3 = 5$, $x \geq 1$. 3

15. (a) Solve the equation $\sin 2x^\circ + 6 \cos x^\circ = 0$ for $0 \leq x < 360$. 4
- (b) Hence solve $\sin 4x^\circ + 6 \cos 2x^\circ = 0$ for $0 \leq x < 360$. 1
-
16. The point P has coordinates $(4, k)$.
C is the centre of the circle with equation $(x-1)^2 + (y+2)^2 = 25$.
- (a) Show that the distance between the points P and C is given by $\sqrt{k^2 + 4k + 13}$. 2
- (b) Hence, or otherwise, find the range of values of k such that P lies outside the circle. 4
-
17. (a) Express $(\sin x - \cos x)^2$ in the form $p + q \sin rx$ where p, q and r are integers. 3
- (b) Hence, find $\int (\sin x - \cos x)^2 dx$. 2

[END OF QUESTION PAPER]

FOR OFFICIAL USE



| | | | | | |
|--|--|--|--|--|--|
| | | | | | |
|--|--|--|--|--|--|

National
Qualifications
2019

Mark

| |
|--|
| |
|--|

X847/76/01

**Mathematics Paper 1 (Non-calculator)
Answer booklet**

THURSDAY, 2 MAY
9:00 AM – 10:30 AM



Fill in these boxes and read what is printed below.

Full name of centre

| |
|--|
| |
|--|

Town

| |
|--|
| |
|--|

Forename(s)

| |
|--|
| |
|--|

Surname

| |
|--|
| |
|--|

Number of seat

| |
|--|
| |
|--|

Date of birth

Day

| | |
|--|--|
| | |
|--|--|

Month

| | |
|--|--|
| | |
|--|--|

Year

| | |
|--|--|
| | |
|--|--|

Scottish candidate number

| | | | | | | | | | |
|--|--|--|--|--|--|--|--|--|--|
| | | | | | | | | | |
|--|--|--|--|--|--|--|--|--|--|

Write your answers clearly in the spaces provided in the answer booklet. The size of the space provided for an answer is not an indication of how much to write. You do not need to use all the space.

Additional space for answers is provided at the end of the answer booklet. If you use this space you must clearly identify the question number you are attempting.

Use **blue** or **black** ink.

Before leaving the examination room you must give your answer booklet to the Invigilator; if you do not, you may lose all the marks for this paper.





National
Qualifications
2019

X847/76/12

**Mathematics
Paper 2**

THURSDAY, 2 MAY
11:00 AM – 12:45 PM

Total marks — 80

Attempt ALL questions.

You may use a calculator.

To earn full marks you must show your working in your answers.

State the units for your answer where appropriate.

You will not earn marks for answers obtained by readings from scale drawings.

Write your answers clearly in the spaces provided in the answer booklet. The size of the space provided for an answer is not an indication of how much to write. You do not need to use all the space.

Additional space for answers is provided at the end of the answer booklet. If you use this space you must clearly identify the question number you are attempting.

Use **blue** or **black** ink.

Before leaving the examination room you must give your answer booklet to the Invigilator; if you do not, you may lose all the marks for this paper.



* X 8 4 7 7 6 1 2 *

FORMULAE LIST

Circle

The equation $x^2 + y^2 + 2gx + 2fy + c = 0$ represents a circle centre $(-g, -f)$ and radius $\sqrt{g^2 + f^2 - c}$.

The equation $(x - a)^2 + (y - b)^2 = r^2$ represents a circle centre (a, b) and radius r .

Scalar product

$\mathbf{a} \cdot \mathbf{b} = |\mathbf{a}| |\mathbf{b}| \cos \theta$, where θ is the angle between \mathbf{a} and \mathbf{b}

or $\mathbf{a} \cdot \mathbf{b} = a_1 b_1 + a_2 b_2 + a_3 b_3$ where $\mathbf{a} = \begin{pmatrix} a_1 \\ a_2 \\ a_3 \end{pmatrix}$ and $\mathbf{b} = \begin{pmatrix} b_1 \\ b_2 \\ b_3 \end{pmatrix}$.

Trigonometric formulae

$$\sin(A \pm B) = \sin A \cos B \pm \cos A \sin B$$

$$\cos(A \pm B) = \cos A \cos B \mp \sin A \sin B$$

$$\sin 2A = 2 \sin A \cos A$$

$$\cos 2A = \cos^2 A - \sin^2 A$$

$$= 2 \cos^2 A - 1$$

$$= 1 - 2 \sin^2 A$$

Table of standard derivatives

| $f(x)$ | $f'(x)$ |
|-----------|--------------|
| $\sin ax$ | $a \cos ax$ |
| $\cos ax$ | $-a \sin ax$ |

Table of standard integrals

| $f(x)$ | $\int f(x) dx$ |
|-----------|----------------------------|
| $\sin ax$ | $-\frac{1}{a} \cos ax + c$ |
| $\cos ax$ | $\frac{1}{a} \sin ax + c$ |

Attempt ALL questions

Total marks — 80

1. Triangle ABC has vertices $A(-5, -12)$, $B(11, -8)$ and $C(-3, 6)$.

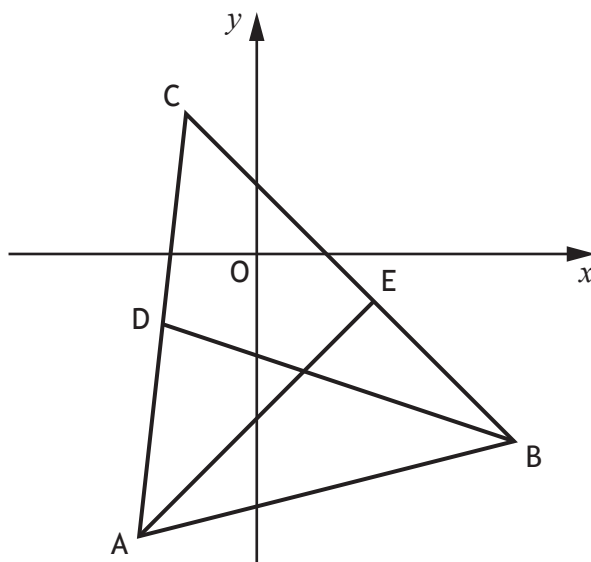

- (a) Find the equation of the median BD. 3
- (b) Find the equation of the altitude AE. 3
- (c) Find the coordinates of the point of intersection of BD and AE. 2
2. Find $\int (6\sqrt{x} - 4x^{-3} + 5) dx$. 4

[Turn over

3. E,ABCD is a rectangular based pyramid.

$$\vec{AB} = \mathbf{p}, \vec{AD} = \mathbf{q} \text{ and } \vec{AE} = \mathbf{r}.$$

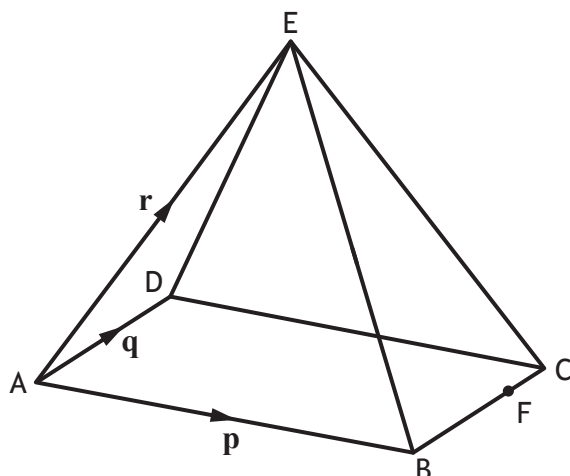

- (a) Express \vec{BE} in terms of \mathbf{p} and \mathbf{r} .

1

Point F divides BC in the ratio 3:1.

- (b) Express vector \vec{EF} in terms of \mathbf{p} , \mathbf{q} and \mathbf{r} .

2

4. In a forest, the population of a species of mouse is falling by 2.7% each year.

To increase the population scientists plan to release 30 mice into the forest at the end of March each year.

- (a) u_n is the estimated population of mice at the start of April, n years after the population was first estimated.

It is known that u_n and u_{n+1} satisfy the recurrence relation $u_{n+1} = au_n + b$.

State the values of a and b .

1

The scientists continue to release this species of mouse each year.

- (b) (i) Explain why the estimated population of mice will stabilise in the long term.

1

- (ii) Calculate the long term population to the nearest hundred.

2

5. The diagram below shows the graph of a cubic function $y = g(x)$, with stationary points at $x = -2$ and $x = 4$.

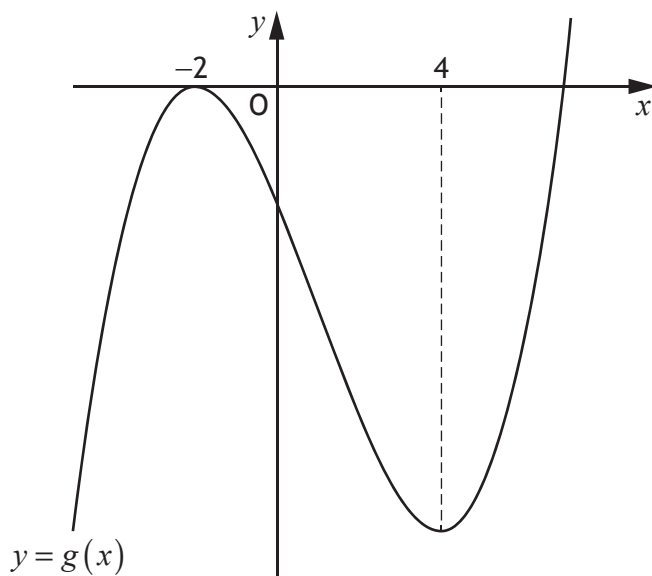

On the diagram in your answer booklet, sketch the graph of $y = g'(x)$.

2

6. (a) Express $2 \cos x^\circ - 3 \sin x^\circ$ in the form $k \cos(x + a)^\circ$ where $k > 0$ and $0 \leq a < 360$. 4
- (b) Hence solve $2 \cos x^\circ - 3 \sin x^\circ = 3$ for $0 \leq x < 360$. 3

7. (a) Express $-6x^2 + 24x - 25$ in the form $p(x + q)^2 + r$. 3

- (b) Given that $f(x) = -2x^3 + 12x^2 - 25x + 9$,
show that $f(x)$ is strictly decreasing for all $x \in \mathbb{R}$. 3

[Turn over

8. A function, f , is given by $f(x) = \sqrt[3]{x} + 8$.

The domain of f is $1 \leq x \leq 1000$, $x \in \mathbb{R}$.

The inverse function, f^{-1} , exists.

(a) Find $f^{-1}(x)$.

3

(b) State the domain of f^{-1} .

1

9. Electricity on a spacecraft can be produced by a type of nuclear generator.

The electrical power produced by this generator can be modelled by

$$P_t = 120e^{-0.0079t}$$

where P_t is the electrical power produced, in watts, after t years.

(a) Determine the electrical power initially produced by the generator.

1

(b) Calculate how long it takes for the electrical power produced by the generator to reduce by 15%.

4

10. (a) Show that $(x+3)$ is a factor of $3x^4 + 10x^3 + x^2 - 8x - 6$.

2

(b) Hence, or otherwise, factorise $3x^4 + 10x^3 + x^2 - 8x - 6$ fully.

5

11. A manufacturer of chocolates is launching a new product in novelty shaped cardboard boxes.

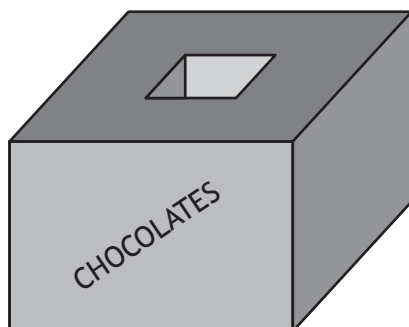

The box is a cuboid with a cuboid shaped tunnel through it.

- The height of the box is h centimetres
- The top of the box is a square of side $3x$ centimetres
- The end of the tunnel is a square of side x centimetres
- The volume of the box is 2000 cm^3

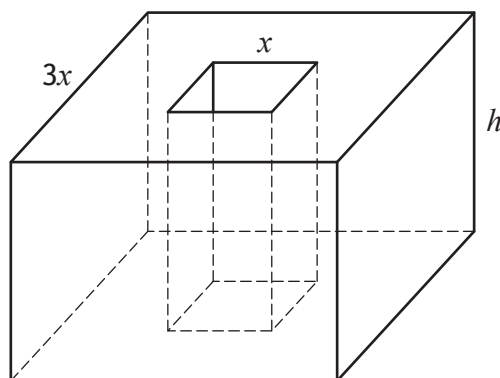

- (a) Show that the total surface area, $A \text{ cm}^2$, of the box is given by

$$A = 16x^2 + \frac{4000}{x}.$$

3

- (b) To minimise the cost of production, the surface area, A , of the box should be as small as possible.

Find the minimum value of A .

6

[Turn over

12. Two variables, x and y , are connected by the equation $y = ab^x$.
The graph of $\log_4 y$ against x is a straight line as shown.

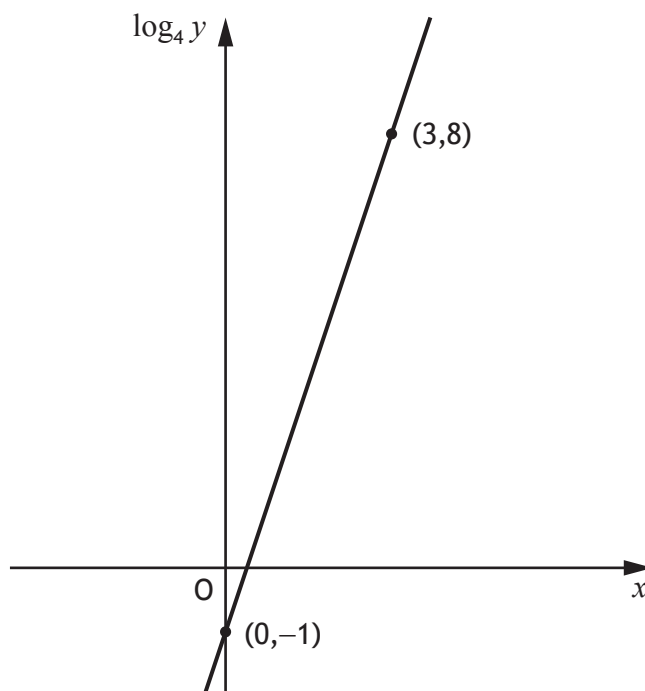

Find the values of a and b .

5

13. For a function, f , defined on the set of real numbers, \mathbb{R} , it is known that
- the rate of change of f with respect to x is given by $3x^2 - 16x + 11$
 - the graph with equation $y = f(x)$ crosses the x -axis at $(7, 0)$.

Express $f(x)$ in terms of x .

5

14. The vectors \mathbf{u} and \mathbf{v} are such that

- $|\mathbf{u}| = 4$
- $|\mathbf{v}| = 5$
- $\mathbf{u} \cdot (\mathbf{u} + \mathbf{v}) = 21$

Determine the size of the angle between the vectors \mathbf{u} and \mathbf{v} .

4

15. A circle has centre $C(8,12)$.
The point $P(5,13)$ lies on the circle as shown.

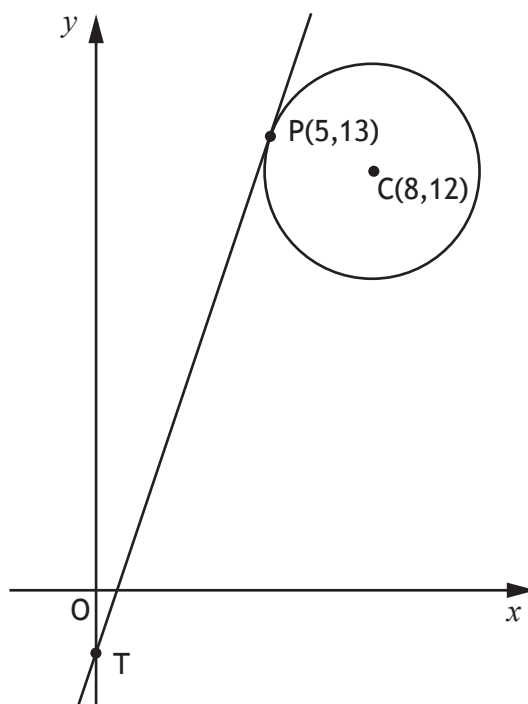

- (a) Find the equation of the tangent at P. 3

The tangent from P meets the y -axis at the point T.

- (b) (i) State the coordinates of T. 1
(ii) Find the equation of the circle that passes through the points C, P and T. 3

[END OF QUESTION PAPER]